

EM5700M-BLK

Single Door Monitored

EM5700M-BLK DESCRIPTION

The **LOX EM5700M-BLK** Black Anodised Series product line is a comprehensive Electro Magnetic Lock range with up to **580kg** holding force. It is one of the most reliable and most successful Electro Magnetic Locks in the Australian market.

THE MONITORED MAGNETIC LOCKS HAVE:

- A built-in Hall Effect Sensor for monitoring the lock/unlock status of the locking device (LSS – Lock Status Sensor)
- A built-in reed switch contact for monitoring the open/closed status of the door (DSS – Door Status Sensor)
- Highly visible red/green LED Status Light
- Anti-Tamper-Fixing-Plate (monitored version only) to avoid hostile attacks targeted on the dome-nut-fixing bolt of the Armature Plate



EM5700M-BLK
MONITORED SINGLE ELECTRO MAGNETIC LOCK

SPECIFICATIONS

EM5700M-BLK	SINGLE ELECTRO MAGNETIC LOCK MONITORED
HOLDING STRENGTH	UP TO 580KG, TESTED TO 1 MILLION CYCLES
VOLTAGE/CURRENT	DUAL VOLTAGE 12/24VDC 12VDC = 500mA 24VDC = 260mA
APPROVALS	UP TO 4 HOUR FIRE RATED TO A.S STANDARD, CE & C-TICK
LSS MONITORING	LSS LOCK STATUS SENSOR (HALL EFFECT) 
DSS MONITORING	DOOR STATUS SENSOR (REED SWITCH)
LED LIGHT STATUS	LED LIGHT STATUS INDICATES LOCKED OR UNLOCKED STATUS
ENVIRONMENTAL	OPERATIONAL TEMPERATURE RANGE - 20 DEG. C TO 60 DEG. C.

LOX
LOCKING

LOX LOCKING PTY LTD | www.loxlocking.com.au

LOX
BLK

EM5700M-BLK

Single Door Monitored

PRODUCT DIMENSIONS

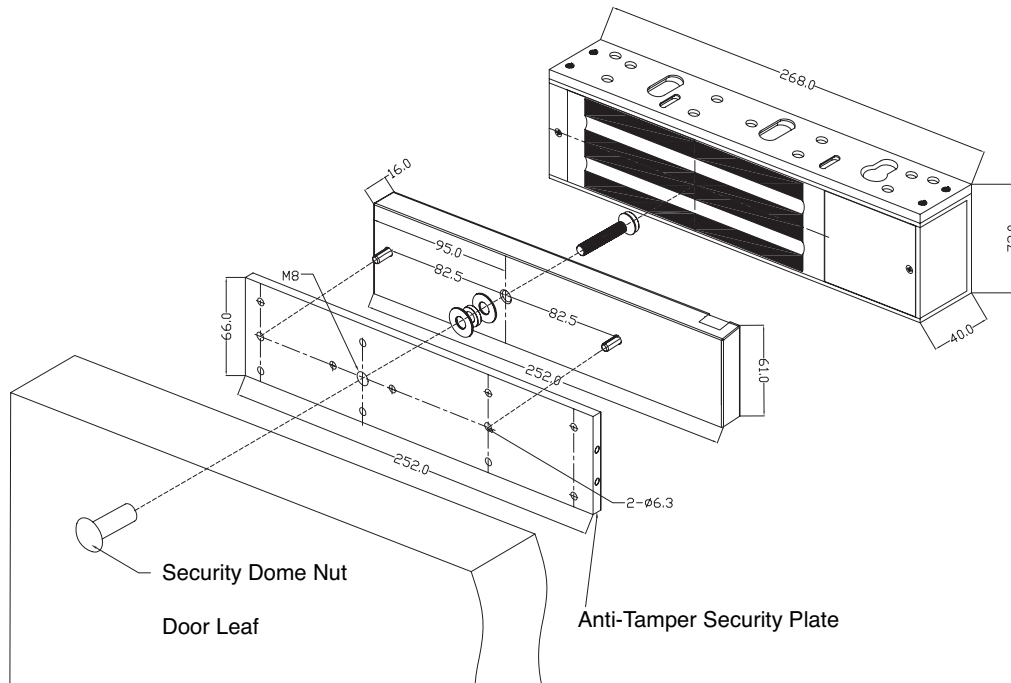

Dimensions (mm)

EM5700M-BLK FACTS

- Black Anodised Body
- Door and Lock Status monitoring Sensor (DSS & LSS with monitored models)
- Built-in varistor (MOV) surge protection
- CE/RCM Approvals
- Anti Tamper Mounting Plate
- High visibility red/green Status Light Panel
- Lifetime warranty
- Up to 4 hour fire rated to AS Standard
- No residual magnetism

ACCESSORIES



EM5700-MP-BLK

LOX MOUNTING PLATE FOR EM5700M-BLK



AMGB1-12-BLK (ON REQUEST)

LOX U SHAPE ARMATURE HOLDER FOR GLASS DOORS EM5700M-BLK & EM5700DM-BLK



AMZB1-DSS-BLK

LOX L & Z BRACKET FOR INWARDS OPENING DOORS EM5700BLK



AMAB1-DSS-BLK (ON REQUEST)

LOX ARMATURE HOLDER AND DRESS PLATE FOR GLASS DOORS EM5700M-BLK & EM5700DM-BLK

LOX
LOCKING

LOX LOCKING PTY LTD | www.loxlocking.com.au

LOX
BLK