

ELECTROMAGNETIC LOCKS 580KG

EM5700 / EM5700D / EM5700M / EM5700DM

INSTALLATION MANUAL

INTRODUCTION:

The **EM5700** is a 580kg single magnetic lock and **EM5700D** is a double magnetic lock, both unmonitored. The **EM5700M** is a 580kg single magnetic lock and **EM5700DM** is a double magnetic lock, both monitored.

The **Lock Status Switch (LSS)** indicates if the lock is powered and the magnetic bond is active using a Hall Effect crystal. The output is an onboard relay, and the dual back-light indicator.

The **Door Status Sensor (DSS)** is a passive reed switch for monitoring of door status, used in access control for door status. Reed does not rely on power to operate.

The **EM5700M/DMs** are supplied with a mounting plate to assist in mounting the armature plate.

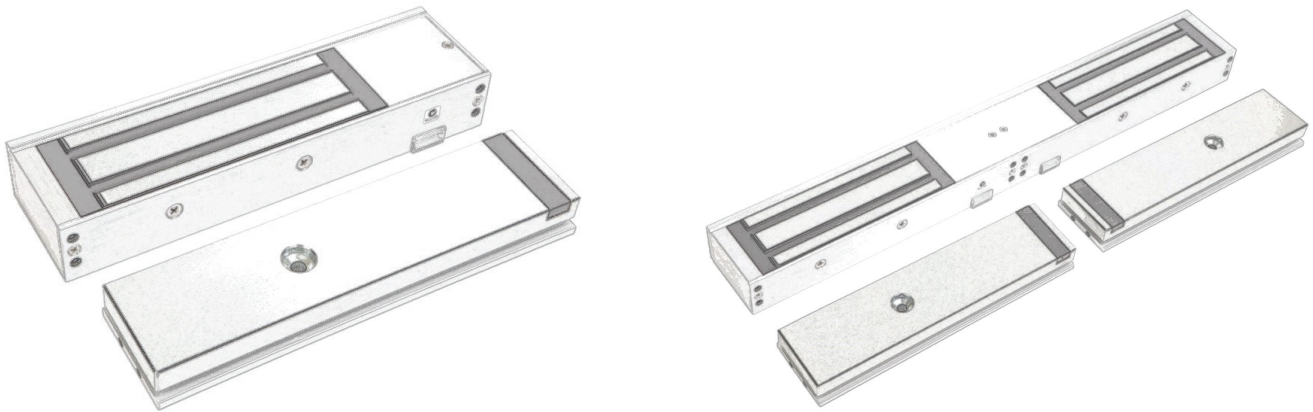

DUAL BACKLIGHT STATUS:

BACKLIGHT INDICATOR OFF	RELAY DE-ENERGIZED	NO POWER ON MAGNETIC LOCK
BACKLIGHT INDICATOR RED	RELAY DE-ENERGIZED	POWER ON MAGNETIC LOCK AND DOOR IS OPEN
BACKLIGHT INDICATOR GREEN	RELAY ENERGIZED	POWER ON MAGNETIC LOCK AND DOOR LOCKED

POWER SETTING AND INPUT:

The (+) lead of the power source is connected to terminal 1 of the terminal block and the (-) lead is connected to terminal 2 (-). The operating switch must be installed between the power source and the magnetic lock to reduce operating time of the magnetic lock to a minimum. The electromagnetic lock requires a filtered and regulated DC power source.

RED jumper (default setting) is 24 volts, and BLUE is 12 volts.

Please note: These voltage shunts must be set correctly before 12 VDC or 24 VDC power is supplied to the Electromagnetic Lock to prevent damage to the unit.

POWER INPUT	EM5700 / EM5700M	EM5700D / EM5700DM
12 VDC	0.50 A	2 × 0.50 A
24 VDC	0.26 A	2 × 0.26 A

ELECTROMAGNETIC LOCKS 580KG

EM5700 / EM5700D / EM5700M / EM5700DM

INSTALLATION MANUAL

INSTALLATION TIPS:

The Armature Plate must remain flexible - the armature plate must be remained movable to allow surface alignment with the magnet face. The magnetic lock will lose holding force without this floating alignment.

Do not trim the rubber washer mounted on the head of the armature center bolt. Trimming rubber washers will adversely affect the release of the armature plate from the magnetic lock.

IMPORTANT SAFETY REQUIREMENTS

Apply thread-locker glue (e.g. Loctite) to the thread of the Armature-Plate-Fixing Screw (Allen-Screw) to prevent from becoming loose.

Locks should be inspected at regular intervals to ascertain the safety functionality.

The supplied Allen screws cater for maximum door thickness of 45mm.

TROUBLE SHOOTING:

PROBLEM	POSSIBLE CAUSE	SOLUTION
DOOR WILL NOT LOCK	NO DC VOLTAGE TO LOCK. LOOSE WIRE ON TERMINAL STRIP	CHECK POWER SUPPLY AND WIRING TO MAGNETIC LOCK
REDUCED HOLDING FORCE	BAD PHYSICAL CONTACT BETWEEN ARMATURE PLATE AND FACE OF MAGNET. INCORRECT VOLTAGE JUMPER SETTING	ENSURE MATING SURFACES ARE CLEAN AND IN PROPER ALIGNMENT AND THE ARMATURE PLATE FLOATS FREELY. CHECK MAGNETIC LOCK FOR LOW VOLTAGE OR WRONG VOLTAGE SETTING
DELAY IN DOOR RELEASE	CIRCUIT SWITCH IS NOT BETWEEN MAGNETIC LOCK AND POWER SOURCE. SECONDARY DIODE INSTALLED ACROSS MAGNETIC LOCK	RE-WIRE CIRCUIT SWITCH BETWEEN MAGNETIC LOCK AND POWER SOURCE. REMOVE ANY INSTALLED DIODE. VOLTAGE SPIKE PROTECTION IS ON THE PCB.
LED STATUS IS INCORRECT	MISALIGNMENT OF ARMATURE PLATE. REED SWITCH LOCATED IN WRONG POSITION IN MAGNETIC BLOCK. INCORRECT VOLTAGE SETTING	CHECK ALIGNMENT OF ARMATURE PLATE. ADJUST JUMPER TO CORRECT VOLTAGE.

MAINTENANCE:

Contacting surfaces of the electromagnet and armature plate must be kept free of contaminating materials. Surfaces should be cleaned periodically with a non-abrasive cleaner. Do not spray the electromagnet or armature plate surface with any lacquer chemical, this will create problems with the release of the magnetic lock and armature plates.

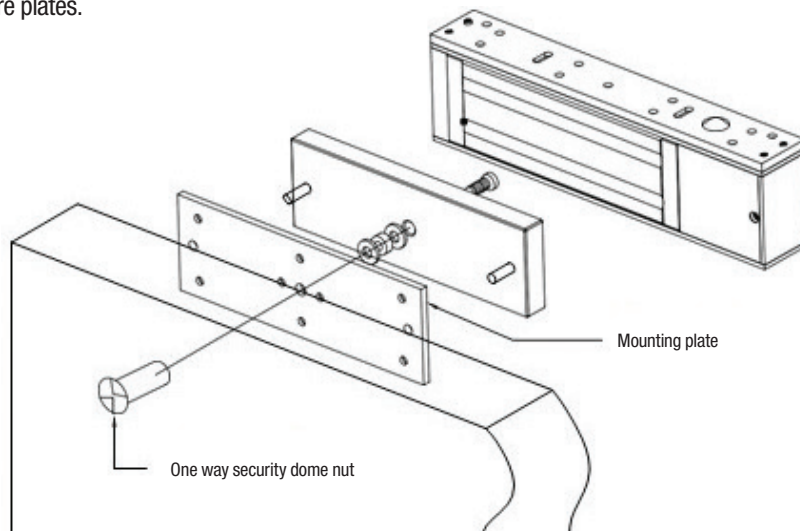

ELECTROMAGNETIC LOCKS 580KG

EM5700 / EM5700D / EM5700M / EM5700DM

INSTALLATION MANUAL

WIRING AND CONNECTIONS:

EM5700M / EM5700DM

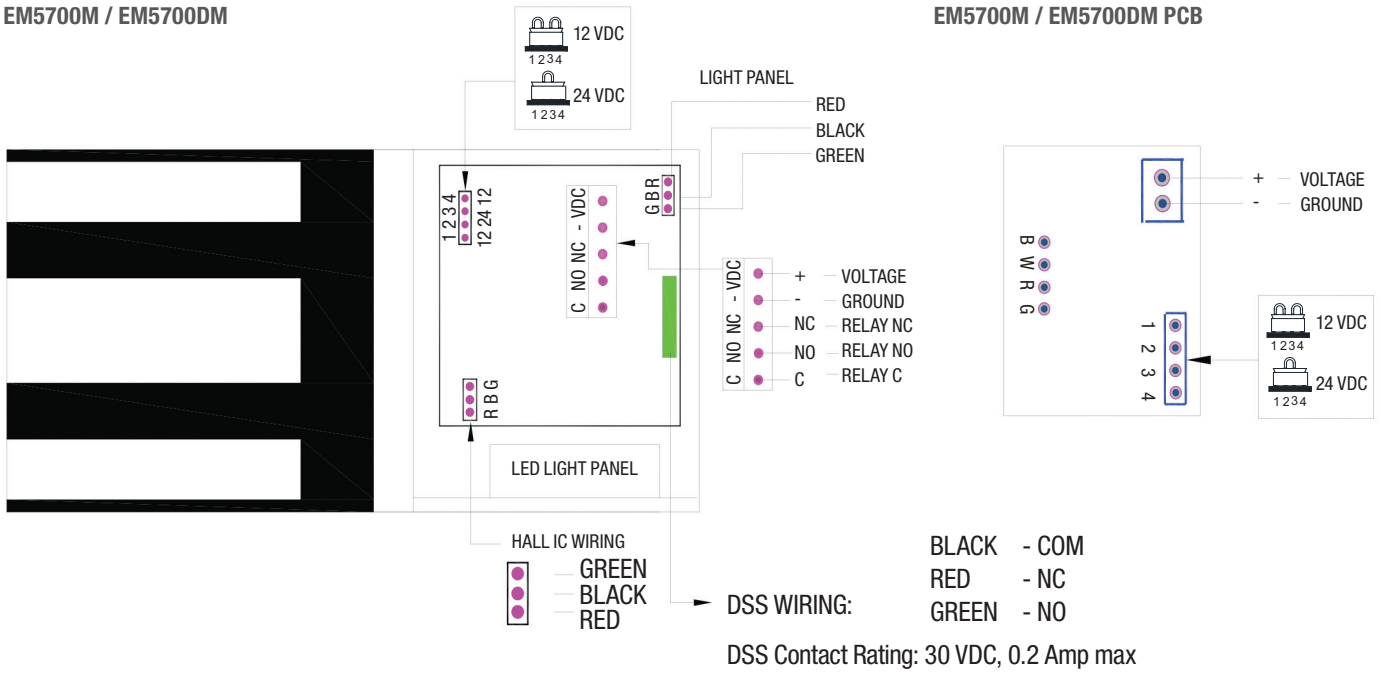

ELECTROMAGNETIC LOCKS 580KG EM5700 / EM5700D / EM5700M / EM5700DM INSTALLATION MANUAL

ARMATURE MOUNTING PLATE DETAIL:

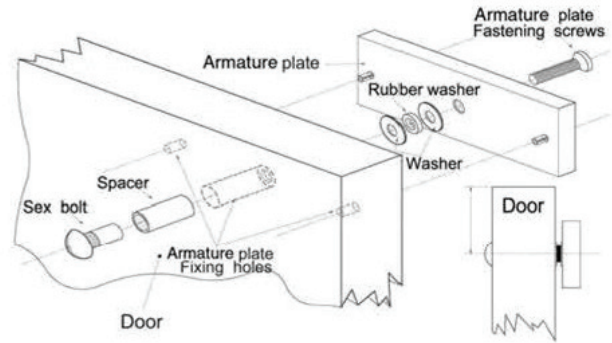
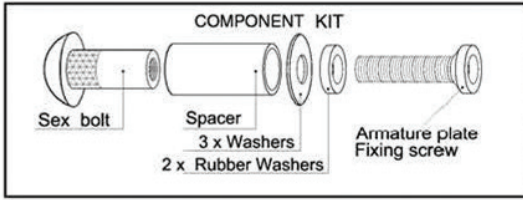

Armature plates must be installed with the components shown above. These components are provided with each electromagnetic lock.

Armature plates must be fixed as shown above. Do not over tighten the fixing screw. The armature must be allowed to 'float' on the rubber washer.

(TO AVOID MALFUNCTION OF THE LOCK DO NOT USE PARTS OTHER THAN THOSE PROVIDED ABOVE)

TYPICAL FIXING OF MAGNETIC LOCK ON IN-SWINGING DOOR



ADJUSTABLE L BRACKET

Adjustable L Bracket is for flush transom or narrow header.



ADJUSTABLE L ARRANGEMENT

L Bracket is for narrow header.

METHODS OF FIXING MAGNETIC LOCKS ON DIFFERENT FRAME PROFILES

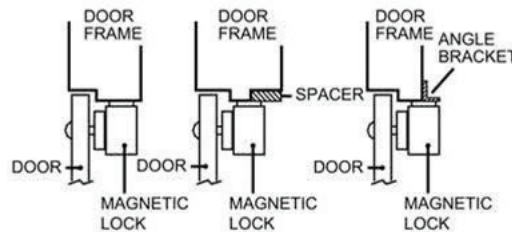

FIXING ARMATURE PLATE ON FRAMELESS GLASS DOORS

