

WatchIN™

Industrial Grade 3 Detector

Dual Technology Industrial Detector



Model: RK325DT

Installation Instructions - Relay & BUS Modes

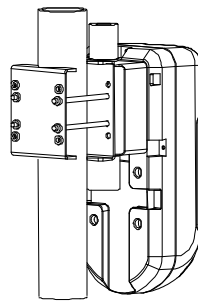
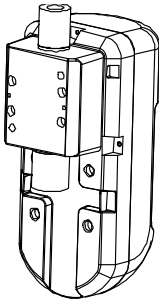
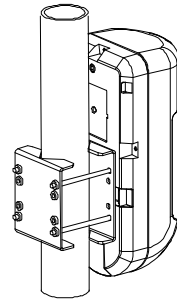
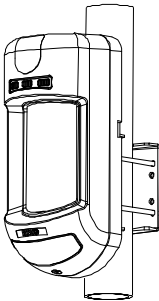
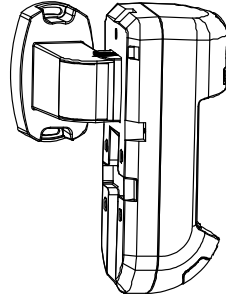
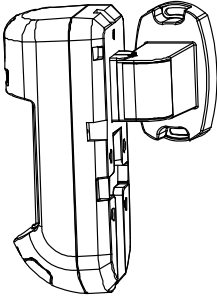
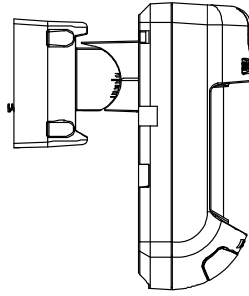
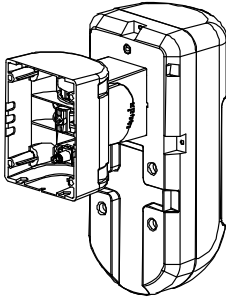

Table of Contents

Relay Mode Installation	4
Introduction	4
Mounting	4
Mounting Considerations	4
Wall Mount Installation	5
Flat Mounting:	5
45° angle Mounting (Left side mounting)	5
Changing Back Tamper position	6
Terminal Wiring	6
DIP Switch Settings	7
Microwave Adjustment	7
Walk test	7
LEDs Display	8
Relay Mode / BUS Mode Jumper	8
TRIPLE EOL Jumpers	9
Standard Swivel Installation	10
Wall Mounting	10
Replacing Lenses	12
Lens Types	13
Technical Specification	15
Ordering Information	15
BUS Mode Installation	16
Introduction	16
Terminal Wiring	16
Cover and Back Tamper	16
Cover Tamper Only	16
Cover Tamper to Zone Input	16
DIP Switch Settings	17
ProSYS Programming (from ProSYS software version 7.xx and above)	17
Adding / Deleting the WatchIN DT	17
Configuring the WatchIN DT Parameters	18
System Parameters	20

Relay Mode Installation



Introduction

RISCO Group's Dual Technology Grade 3 Industrial detector, WatchIN, is a unique detector with signal processing based on two Passive Infrared (PIR) channels and two Microwave (MW) channels. The detector can operate as a regular relay detector connected to any control panel, or as a BUS accessory when connected to RISCO Group's ProSYS control panel via the RS485 BUS, thus having unique remote control and diagnostic capabilities.

The instructions describe herein, describe the WatchIN in Relay & BUS mode. For detailed information regarding BUS mode installation, refer to BUS Mode installation chapter, page 16.

Mounting

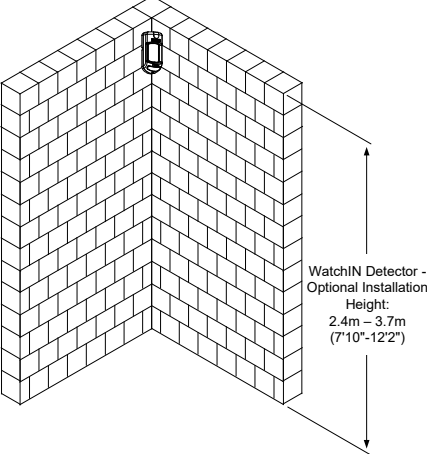
Mounting Considerations

 <p>WatchIN Detector - Optional Installation Height: 2.4m – 3.7m (7'10"–12'2")</p>	<p>Typical Height: 2.4m (7'10") Default Lens: Wide angle 25m (88') 90° (RL325)</p> 
---	---

For optimum detection, select a location that is likely to intercept an intruder moving across the coverage pattern at a 45° trajectory.

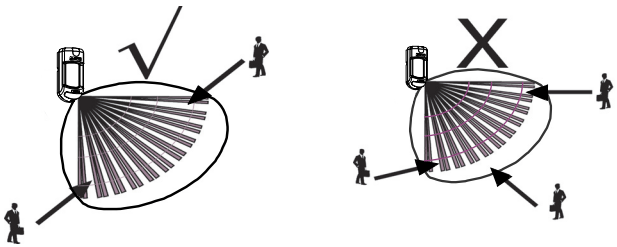

Wall Mount Installation

Note:

The installation knockouts numbering are marked on the back plate.

1. Open WatchIN front cover (unlock C1, Figure 1).
2. Release internal base (unlock I1, Figure 2).
3. Select mounting installation as follows:

Flat Mounting:

Open knockouts on external base (Figure 3).

- B1 - B4: Wall mounting knockouts
- T1: Back tamper knockout
- W2 / W3: Wires entry knockouts

45° angle Mounting (Left side mounting):

- a. Open knockouts on external base (Figure 3)
 - L1, L2: Left mounting knockouts
 - T3: Left tamper knockout
 - W5 / W6: Wire entry knockouts
- b. Remove tamper spring
- c. Replace tamper bracket (Item 1) with supplied flat tamper bracket (Item 2).



- d. Insert Tamper lever B onto T5 and T3 and secure screw A (Figure 3)
4. Insert external wires through external base W2, W3 (Flat Mounting) or W5, W6 (Left side mounting) (Figure 3).
 5. Secure external base to the wall.
 6. Insert external wires and tamper wires through internal base (Figure 4).
 7. Secure internal base to external base (lock I1, Figure 2).
 8. Close the front cover (Lock C1, Figure 1) after wiring and setting DIP switches.
 9. Walk test the detector.

Figure 1

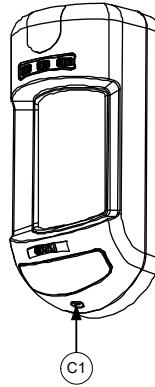

Figure 2

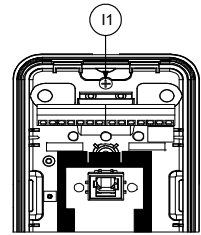

Figure 3

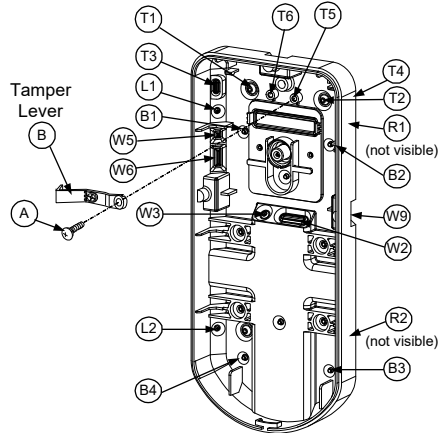
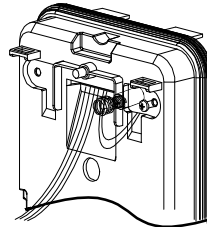

Figure 4



Note:

For 45° right side installation use the equivalent units on the external base as follows:

Knockouts Description	Left	Right
Mounting Knockouts	L1, L2	R1, R2
Tamper spring knockouts	T1, T3	T2, T4
Tamper screw anchor	T5	T6
Wiring Knockouts	W5, W6	W7, W8

Changing Back Tamper position

The back tamper is by default secured on the right side of the internal base (Rear view). If you wish to move it to the left side (rear view), do the following (Figure 5):

1. Remove tamper screw 1 in order to release the tamper from position 7.
2. Ensure tamper spring 2 rests over tamper wire base 4.
3. Ensure plastic tamper bracket 3 rests over both 2 and 4.
4. Secure tamper screw 1 into 3 over position 6.

Figure 5

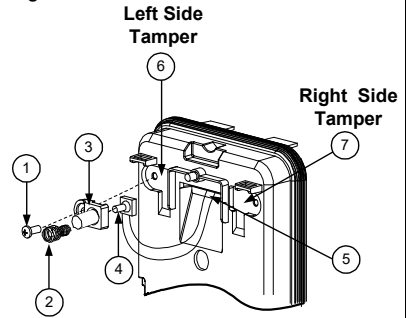

Notes:

1. Verify that you hear a "Click" when attaching the tamper spring to the wall.
2. For pole installation, the tamper can be moved to the bottom right-hand side of the internal base.

Terminal Wiring

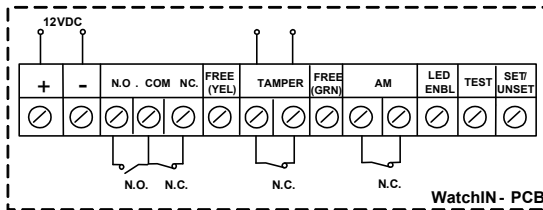

WatchIN - PCB

+, -	12 VDC
N.O	Form C relay, 30VDC 1A NORMAL
COM	ALARM
N.C	
FREE YEL	This terminal is a free pin that can be used to connect wires and EOL resistors
TAMPER	N.C relay, 24VDC , 0.1A
FREE GRN	This terminal is a free pin that can be used to connect wires and EOL resistors
AM	Normally closed AM relay output (24VDC, 0.1A) indicates Anti Masking alarm or any trouble in the detector. Note: When a vibration detector is installed and DIP 8 is defined as Enabled this relay also opens momentarily when vibration event occurs.
LED ENBL	Used to remotely control the LEDs when DIP 1 is set to ON. Enable: input is +12V OR no terminal connection Disable: Connect the input to 0V
TEST	Used to perform remote alarm testing to the detector by applying 0 volts to this terminal. Success: Alarm relay is momentarily opened Failure: AM relay is opened

SET/ UNSET	This input enables to control Anti-masking and LEDs operation in accordance to the system status, Set (Arm) / Unset (Disarm). While the system is armed, this feature prevents an intruder from gaining knowledge of the detector's status and disables Anti-masking detection.		
	System Status	Input Status	AM Relay
	Set (Arm)	0V	Off
	Unset (Disarm)	12V or no connection	On*
	* DIP 7 is ON (Anti masking enabled) ** DIP 1 is ON (LEDs enabled) and LEDs ENABLE input terminal is enabled (+12V OR no terminal connection)		

DIP Switch Settings

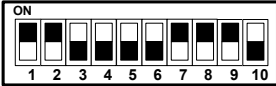

Factory Default

- DIP 1:** LEDs operation
On: LEDs Enabled
Off: LEDs Disabled
- DIP 2-3:** Detection Sensitivity

Sensitivity	DIP2	DIP3
Low	Off	Off
Mid	Off	On
Normal (Default)	On	Off
ACT(Anti-Cloak™ Technology)	On	On

- DIP 4:** Alarm condition
On: PIR or MW
Off: PIR + MW
- DIP 5:** Detector's optics
On: Barrier
Off: Wide angle
- DIP 6:** Red LED /3 LED
On: Red LED only
Off: 3 LEDs
- DIP 7:** Anti masking operation
On: Enabled
Off: Disabled
- DIP 8:** Vibration detection (applicable to versions with Vibration sensor installed)
On: Enabled
Off: Disabled
- DIP 9:** Sway recognition Enable/Disable
On: Enabled
Off: Disabled
- DIP 10:** Green line
On: MW Off during Disarm (unset)
Off: MW On during Disarm (unset)

Note:
Green line is valid when connecting wire from the panel output (arm follow) to the detector set/unset input.

Microwave Adjustment

Adjust Microwave coverage area by using the trimmer on the PCB.



Walk test

Two minutes after applying power, walk test the protected area to verify proper operation.
For installations on uneven surfaces slide the PCB inside the internal base to the appropriate setting according to the desired height (2.4m, 3.0m, 3.7m) as printed on the bottom left corner of the PCB or use the standard swivel accessory.

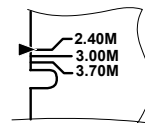

For reducing the detection range, slide the PCB up or tilt the swivel down.

LEDs Display

LED	State	Description
YELLOW	Steady	Indicates PIR detection
	Flashing	Indicates AM (Anti mask) detection
GREEN	Steady	Indicates MW detection
RED	Steady	Indicates ALARM
	Flashing	Indicates malfunctioned communication with ProSYS (BUS mode only)
All LEDs	Flashing (One after another)	Unit initialization on power up

Notes:

1. DIP-Switch 1 should be in ON position to enable LED indications.
2. Only one LED is active at any one time. For example, in the case of both PIR and MW detection, either the steady YELLOW LED or the steady GREEN LED is displayed (the first to detect), followed by the Alarm RED LED.

Relay Mode / BUS Mode Jumper

J-BUS jumper (located on the PCB between the red and green LEDs) is used to define the detector's mode of operation as follows:

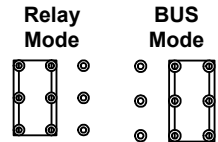

TRIPLE EOL Jumpers

<p>TRIPLE EOL Jumpers</p>		<p>Jumpers J4 and J5 allow the selection of Tamper and Alarm resistance (1K, 2.2K, 4.7K, 5.6K, 6.8K) according to the control panel (see Figure 6 below). Jumper J6 allows the selection of 12K for Anti-Mask.</p> <p>Follow the terminal block connection diagram in Figure 6 when connecting the detector to a Double/Triple End Of Line (DEOL/TEOL) Zone.</p>
----------------------------------	--	--

<p>TAMPER EOL (J4)</p>	<p>ALARM EOL (J5)</p>	<p>AM EOL (J6)</p>
-------------------------------	------------------------------	---------------------------

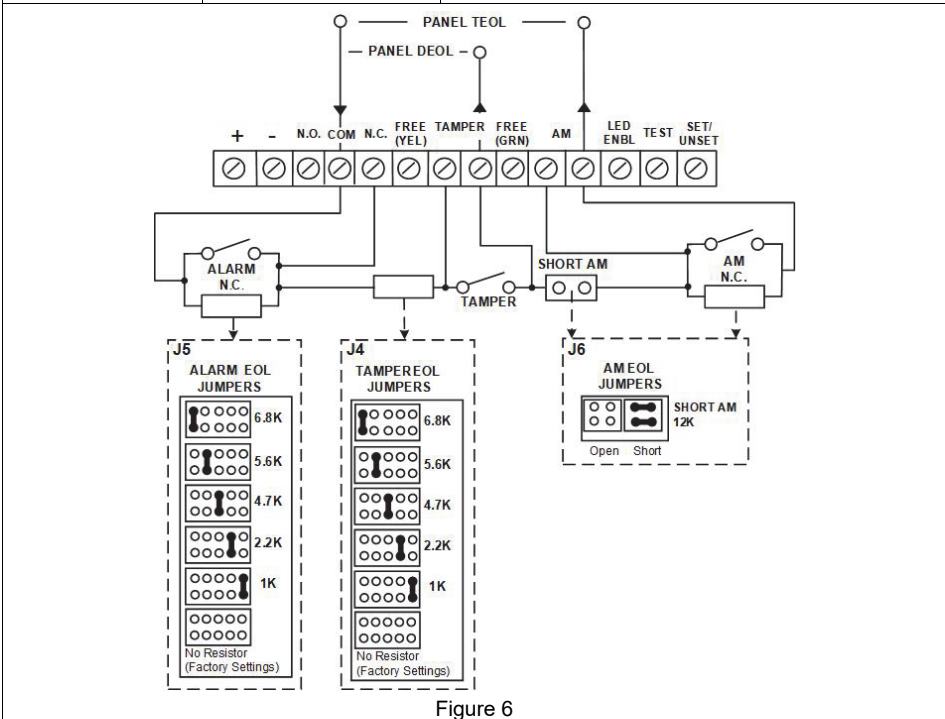

Figure 6

Standard Swivel Installation

The WatchIN detector package contains a standard swivel for flexible installation. Please follow the instructions below for mounting the detector with the Standard Swivel:

1. Open WatchIN front cover (Unlock C1, Figure1).
2. Release internal base (Unlock I1, Figure2).
3. Open knockouts on external base (Figure 7, Detail B)
 - W1: Wires knockout
 - S1,S2: Knockouts for securing external base to Standard Swivel
 - S3: External base locking screw knockout
4. On the swivel accessory remove the required swivel cable wiring knockout S2, S7 or S9 (Figure 7, Detail A).
5. Remove back tamper from the internal base (see “Changing Back Tamper Position” paragraph) and connect it to S5 (Figure 7, Detail A) on the Standard Swivel.

Note:

Ensure that you see the engraved **UP** mark on the upper front face of the swivel.

6. Select the mounting installation type as follows:

Wall Mounting

- a. Insert external cable wiring through knockouts S2, S7 or S9 and extract them (including the tamper wires) through the Swivel Wires Passage (Figure 7, Detail B).
- b. Secure swivel to the wall through holes S1, S3, S6 and S8.

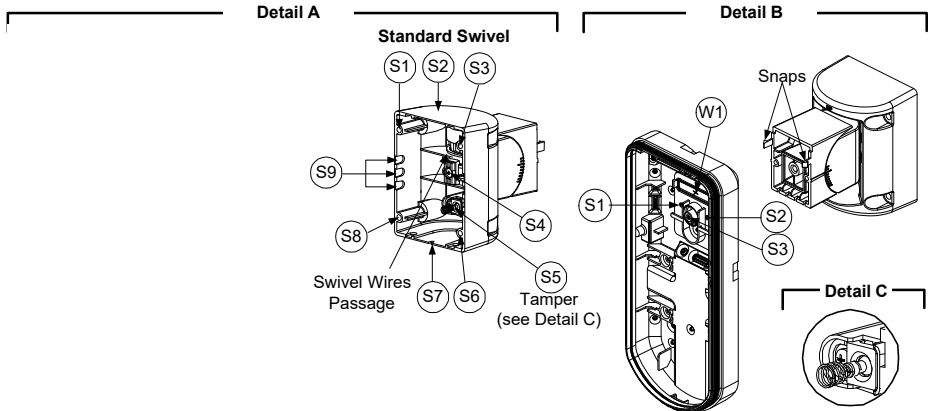

Figure 7

- c. Secure swivel to the wall through holes S1, S3, S6 and S8.
7. Insert tamper wires and external cable wiring from Standard Swivel through knockout W1 on the external base (Figure 7, Detail B).
 8. Connect the external base to the swivel using the dedicated snaps (Figure 8).

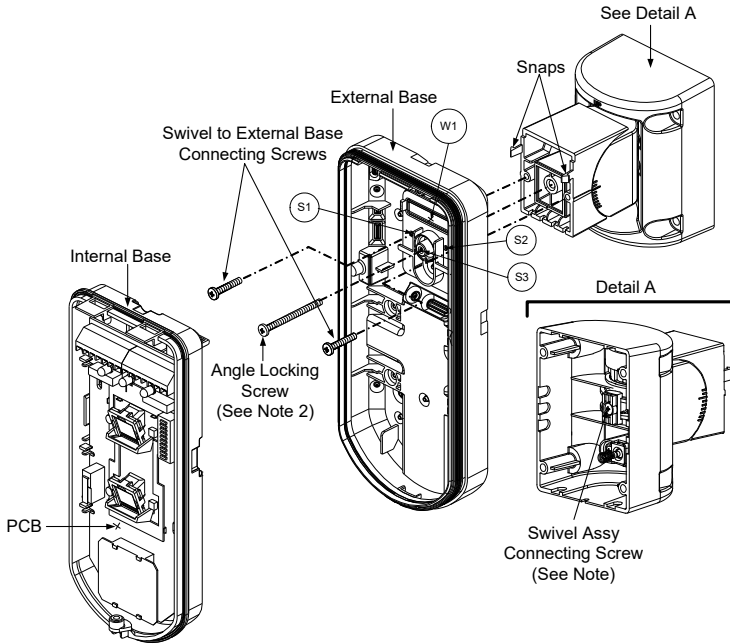

Figure 8

NOTE:

Do not open or close the Swivel Assy Screw since it is used for connecting the swivel parts only.

9. Secure external base to swivel with two screws fastened to knockouts S1 and S2 (Figure 8).
10. Insert the supplied angle locking screw from the external base through the angle locking screw knockout S3 on the external base to the standard swivel (Figure 8).
11. Tilt and Rotate the Standard Swivel to the desired position. Once the Standard Swivel is in the desired position, secure the angle locking screw.
12. Line up the internal base onto the external base. Insert all wiring cables through the internal base.
13. Secure internal base to external base (Lock I1, Figure 2).
14. To readjust the Standard Swivel when the PCB is installed (Figure 9):
 - a. Bend down the black foam located below the RED LED on the PCB (enough to reach the Swivel locking screw).
 - b. Use a Philips screwdriver to release the locking screw (see Figure 9).
 - c. Tilt and/or Rotate the Standard Swivel to the desired position.
 - d. Secure the angle locking screw.

Note:

When marks on the two movable parts are aligned (Figure 8), the Standard Swivel is in 0° vertical /horizontal position. Each click from this position represents shifting of 5° in vertical / horizontal position.

15. Close the front cover (Lock C1, Figure 1) and walk test the detector.

Note:

The screw has to pass through External Base and locked to the swivel.

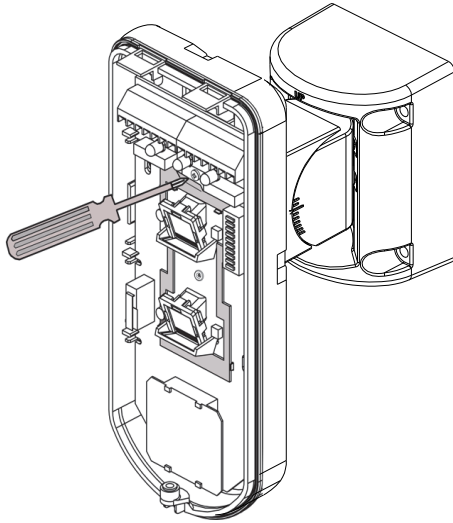
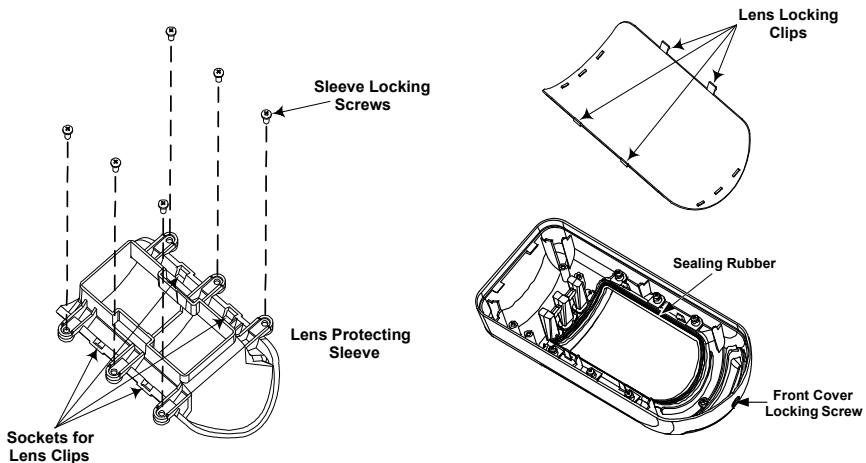

Figure 9

Replacing Lenses

1. Unlock the six screws that hold the lens holding sleeve from the back of the front cover.
2. To release the protective sleeve, gently push the lens from the external side of the front cover.
3. Disconnect the lens from the sleeve by gently pushing the lens clips that secure it to the sleeve.
4. Replace the lens. Place the 4 clips of the lens into the matching holes on the sleeve.
5. Insert the protective sleeve back into place on the front cover. Pay attention to place the sleeve over the sealing rubber.
6. Secure the 6 holding screws back to their place.



Lens Types

Wide angle lens (RL325): Top view

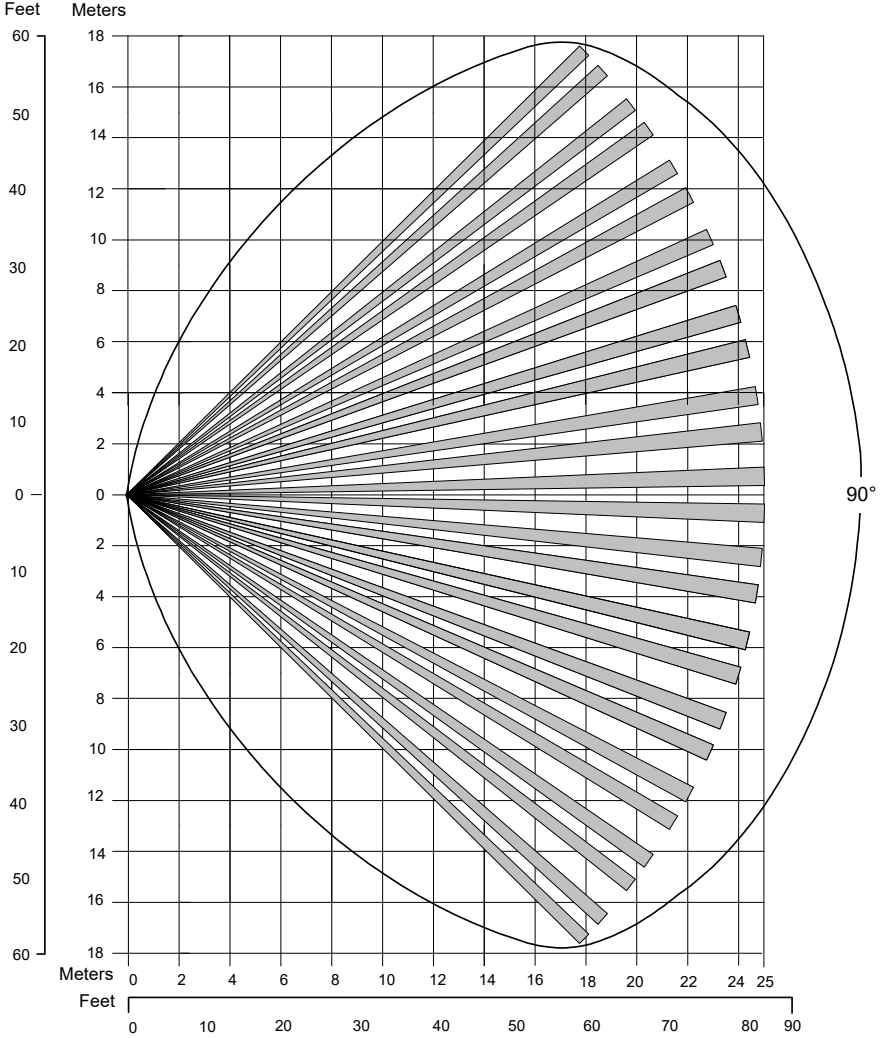

Wide angle lens (RL325): Side View

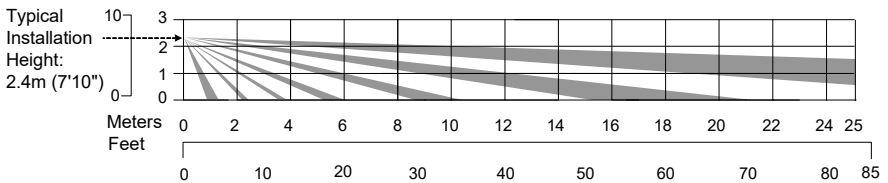

Barrier lens (RL327B): Top view

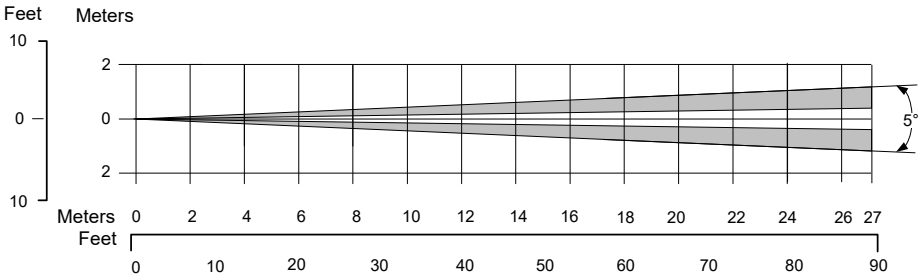

Barrier lens (RL327B): Side view

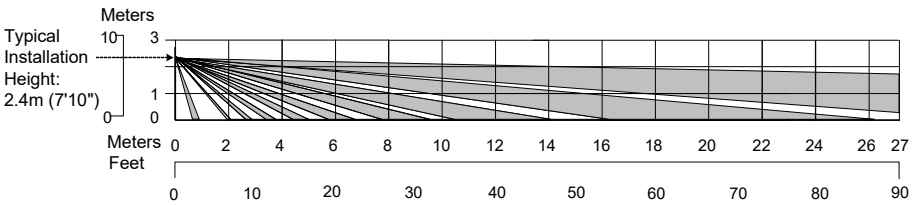

Note:

All detection patterns are assured and approved according to EN50131 in Normal sensitivity settings (factory default).
If you change the sensitivity setting, the actual detection pattern must be assured during installation.

Technical Specification

Electrical	
Current consumption (Relay Mode)	45mA at 12 VDC (Stand by)
	60mA at 12 VDC (MAX with LED ON)
Current consumption (BUS Mode)	30mA at 12 VDC (Stand by),
	45mA at 12 VDC (MAX with LED ON)
Power Output	10dBm
Voltage requirements	9-16 VDC**
Alarm contacts	30 VDC, 1A
AM contacts	24 VDC, 0.1A
Physical	
Size: LxWxD	215 x 95 x 85mm
Weight	0.632 Kg
Environmental	
RF immunity	10V/m (80MHz to 2.7GHz)
Operating temperature	-10°C to 55°C
Storage temperature	-20°C to 60°C

* PIR technology is limited in rough environmental conditions.

** Use a 5A max power supply, using safety-approved wires with a minimum gauge of 20AWG.

Ordering Information

Standard Units

Part Number	Description
RK325DT0000D	WatchIN DT + Swivel
Each of the detectors contains a standard swivel and a replacement barrier lens (P/N engraved on the Lens - RL327B)	

Accessories

Part Number	Description	Weight
RA300B00000A	Barrier Swivel Kit	0.1 Kg
RA300P00000A	Pole Adaptor Kit	0.25 Kg

BUS Mode Installation

Introduction

The information in this section relates to WatchIN DT installation in BUS Mode only. Up to 32 BUS detectors can be installed on the ProSYS RS485 BUS, saving cabling time and enabling remote control and diagnostics.

Terminal Wiring

+,-	Used for the connection of 12VDC power supply. Connect the (+) terminal to the AUX RED and the (-) terminal to the COM BLK of the ProSYS terminals
YELLOW	Used for data communication with the ProSYS. Connect to the terminal to the BUS YEL of the ProSYS
GREEN	Used for data communication with the ProSYS. Connect to the terminal to the BUS GRN of the ProSYS
TAMPER	Used for the wiring for tamper detection, see below
LED ENABLE	Used for the wiring for tamper detection, see below
Note:	
All the terminals not mentioned in the table above are unused.	

Cover and Back Tamper

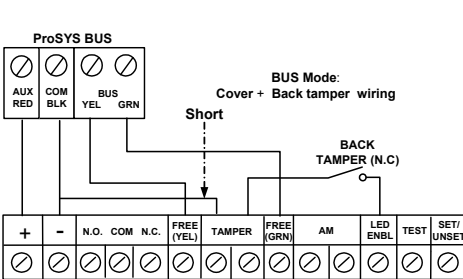

Cover Tamper Only

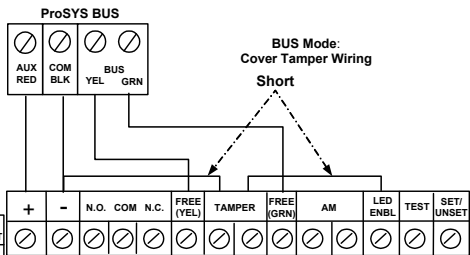

Cover Tamper to Zone Input

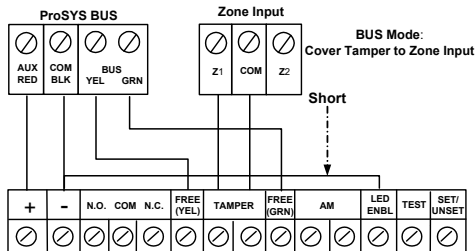

DIP Switch Settings

DIP Switch Number	Description
1 - 5	Used to set the detector ID number. Set the ID number in the same way as for any other ProSYS accessory (Refer to the table below).
6 - 10	Not used

WatchIN ID: DIP Switches 1 - 5

ID	1	2	3	4	5
01	OFF	OFF	OFF	OFF	OFF
02	ON	OFF	OFF	OFF	OFF
03	OFF	ON	OFF	OFF	OFF
04	ON	ON	OFF	OFF	OFF
05	OFF	OFF	ON	OFF	OFF
06	ON	OFF	ON	OFF	OFF
07	OFF	ON	ON	OFF	OFF
08	ON	ON	ON	OFF	OFF
09	OFF	OFF	OFF	ON	OFF
10	ON	OFF	OFF	ON	OFF
11	OFF	ON	OFF	ON	OFF
12	ON	ON	OFF	ON	OFF
13	OFF	OFF	ON	ON	OFF
14	ON	ON	ON	ON	OFF
15	OFF	ON	ON	ON	OFF
16	ON	ON	ON	ON	OFF

ID	1	2	3	4	5
17	OFF	OFF	OFF	OFF	ON
18	ON	OFF	OFF	OFF	ON
19	OFF	ON	OFF	OFF	ON
20	ON	ON	OFF	OFF	ON
21	OFF	OFF	ON	OFF	ON
22	ON	OFF	ON	OFF	ON
23	OFF	ON	ON	OFF	ON
24	ON	ON	ON	OFF	ON
25	OFF	OFF	OFF	ON	ON
26	ON	OFF	OFF	ON	ON
27	OFF	ON	OFF	ON	ON
28	ON	ON	OFF	ON	ON
29	OFF	OFF	ON	ON	ON
30	ON	ON	ON	ON	ON
31	OFF	ON	ON	ON	ON
32	ON	ON	ON	ON	ON

ProSYS Programming (from ProSYS software version 7.xx and above)

The following section describes the additional software programming options, added to the ProSYS software, that concern the settings of the WatchIN DT as a BUS detector. Up to 32 BUS detectors can be added to the system (16 in ProSYS 16) and each of them comes at the expense of a zone in the system.

It is recommend reading and fully understanding the ProSYS Installation and User Manuals, before programming the WatchIN.

Notes:

The WatchIN is compatible with the ProSYS software Version 7.xx and above.

The WatchIN can be programmed via the U/D Software supporting ProSYS software Version 7.xx and above.

For maximum operation stability, it is best NOT to exceed a total of 300 meters (1000 feet) of wiring when connecting the WatchIN to the BUS.

Adding / Deleting the WatchIN DT

The WatchIN is part of an accessory category, BUS zones. Therefore, Adding/Deleting the WatchIN is identical to any other accessory with the following exception:

Each BUS Zone Detector should be assigned to a Regular Zone.

Any BUS detector can be assigned to a physical wired zone or to a virtual zone.

- ◆ **Physical zone:** Any zone on the ProSYS PCB (zones 1-8) or on a wired zone expander (ZE08, ZE16).
- ◆ **Virtual zone:** Any zone on a BUS zone expander defined as BZ08 or BZ16.





Notes:

Virtual BUS zones are cost effective. They enable to expand your system zones without adding physical zone expanders.

The virtual BUS zone expander can be used only for BUS zone detectors.





To add a BUS zone expander select type BZ08 or BZ16 when adding a zone expander (Quick key [7][1][2]).

1. To Add / Delete the WatchIN DT

- From the installer menu enter the Add/Delete menu: Quick Key [7][1][9][5] for BUS Zones detectors.
- Use the  /  or  /  keys to position the cursor over the BUS Zone ID number for which you want to assign (or delete) a detector.

Note:

Make sure that the detector's physical ID number is identical to the ID number you select during programming.



- Place the cursor on the TYPE field and use the  /  key to select IDT25 for the WatchIN DT detector.
- Press  /  to confirm.
- Repeat the process for the other BUS detectors.

2. Assigning the WatchIN DT to a Zone



- From the main installer menu enter Zones: One by One option (Quick key [2][1])
- Select the zone number that you want to assign the BUS detector.

Note:

If you have defined a BUS Zone Expander, select a zone number from the virtual zones (defined by the BUS zone expander).

- Define Partitions, Groups, Zone Type and Zone Sound.
- In the Termination category select [5] BUS Zone followed by  / . The following display appears:

```
Z:001   LINK TO:
ID:01   TYPE=IDT25
```

- Select the BUS zone number to assign to the programmed zone. The type field will be updated automatically when selecting the zone.
- Press  / . The loop response category is not applicable to a BUS zone and the following display appears:



```
Z:001   RESPONSE:
N/A-BUS ZONE
```

- Press  / , assign label and press  / .

Configuring the WatchIN DT Parameters

- To access the WatchIN settings option press [2][0][3] from the main installer menu. The following display appears:

```
B- ZONE PRMS:
ZONE#=001   (0:01)
```

- Select the zone that the BUS zone was assigned to and press  / . You can now program the WatchIN parameters as follows:

Zones Miscellaneous: BUS Zone

Quick Keys	Parameter	Default
[2][0][3][zzz] [1]	LEDS Defines the LEDS operation mode	3 LEDS
[2][0][3][zzz] [1][1]	Off Disables the LEDS operation	
[2][0][3][zzz] [1][2]	Red Only Only the Red led will operate. This option is highly recommended to avoid the	

Quick Keys	Parameter	Default	
	possibility that the intruder will "Learn" the detector behavior.		
[2][0][3][zzz] [1][3]	3 LEDS All 3 LEDs will operate.		
[2][0][3][zzz] [2]	Detection Sensitivity	Normal	
	Defines the sensitivity of the detector(MW + PIR)		
[2][0][3][zzz] [2][1]..[4]	Sensitivity Options 1) Low 3) Normal 2) Medium 4) ACT (Anti-Cloak™ Technology)		
[2][0][3][zzz] [3]	MW Range	Trimmer	
	Defines the microwave channel range (maximum range - 27m)		
[2][0][3][zzz] [3][1]..[7]	MW Range options 1) Minimum 3) 40% 5) 80% 7) Trimmer (MW is defined 2) 20% 4) 60% 6) Maximum by the trimmer setting on the PCB)		
[2][0][3][zzz] [4]	Alarm Logic	PIR and Microwave	
	Determine the detector's logic of defining an alarm.		
[2][0][3][zzz] [4][1]	PIR and Microwave Alarm is activated when both PIR and MW channels detect an alarm (AND Logic)		
[2][0][3][zzz] [4][2]	PIR or Microwave An alarm is activated when either PIR or MW channels detect an alarm (OR Logic)		
[2][0][3][zzz] [5]	Lens Type	Wide Angle	
	Defines the actual Lens of the detector		
[2][0][3][zzz] [5][1]..[2]	Lens Type Options 1) Wide Angle 2) Barrier		
[2][0][3][zzz] [6]	Anti-Mask	Enable	
	Defines the operation of Anti Masking detection		
[2][0][3][zzz] [6][1]..[2]	Anti-Mask Options 1) Disable 2) Enable (Default)		
Quick Keys	Parameter	Default	
[2][0][3][zzz] [7]	Arm/Disarm	No	
	Defines the operation of the LEDs and the anti masking detections while the detector is armed		
[2][0][3][zzz] [7][1]	No AM (Anti masking) is enabled LEDs behave according to the LEDs parameter definition		
[2][0][3][zzz] [7][2]	Yes AM (anti masking) is disabled LEDs are disabled		
[2][0][3][zzz] [9]	Green line The WatchIN includes a Green Line feature that follows environmental guidelines by avoiding surplus emission.		
[2][0][3][zzz] [9][1]	NO Green Line feature in disabled: MW is constantly activated		
[2][0][3][zzz] [9][2]	Yes Green Line feature is enabled		
[2][0][3][zzz] [0]	SWAY This option allows the recognition and immunity of swaing objects in a known patern.		

Quick Keys	Parameter	Default
[2][0][3][zzz] [0][1]	NO	
	Sway is disabled	
[2][0][3][zzz] [0][2]	Yes	
	Sway is enabled	

System Parameters









System: System Control

Quick Keys	Parameter	Default
[1][2][36] (UK Version)	AM=Tamper	Default: No
	Used to determine the operation of Anti Masking detection Yes: Anti mask violation will activate tamper alarm. No: Anti mask violation will be regarded as trouble event.	

Quick Keys	Parameter	Default
[1][2][37]	VBR=Tamper	No
	Used to determine the operation of the vibration detection (applicable to versions with Vibration sensor installed) Yes: Vibration detection will activate tamper alarm. No: Vibration detection will be regarded as trouble event.	

Diagnostics

The ProSYS enables you to test parameters that reflect the operation of the detector.

- From the main user menu press  [4] to access the Maintenance menu.
- Enter the Installer code (or sub-installer) and press  / .
- Press [9] [1] to for the BUS Zones diagnostic menu.
- Enter the digit of the zone that you want to test and then press  / . The system will perform the diagnostics test and a list of test parameters will appear, as indicated in the table below.
- Use the keys  /   /  to view the diagnostics test results.

User Menu: 4) Maintenance → 9) Diagnostic → 1) BUS Zone

Quick Keys	Parameter
[4][9][1][zzz]	Detector Input Voltage: Display the input voltage of the detector. PIR 1 Level: PIR channel 1 DC level. Range 0.1v - 4v PIR 1 Noise Level: PIR channel 1 AC level. Range 0VAC (No noise) - 4VA PIR 2 Level: PIR channel 2 DC level. Range 0.1v - 4v PIR 2 Noise Level: PIR channel 2 AC level. Range 0VAC (No noise) - 4VA MW 1 Level: MW channel 1 DC level Range 0.1v - 4v MW 1 Noise Level: MW channel 1 AC level (0VAC (No noise) - 4VAC) MW 2 Level: MW channel 2 DC level Range 0.1v - 4v MW 2 Noise Level: MW channel 2 AC level (0VAC (No noise) - 4VAC)

Standard Limited Product Warranty (“Limited Warranty”)

RISCO Ltd. (“RISCO”) guarantee RISCO’s hardware products (“Products”) to be free from defects in materials and workmanship when used and stored under normal conditions and in accordance with the instructions for use supplied by RISCO, for a period of (i) 24 months from the date of delivery of the Product (the “Warranty Period”). This Limited Warranty covers the Product only within the country where the Product was originally purchased and only covers Products purchased as new.

Contact with customers only. This Limited Warranty is solely for the benefit of customers who purchased the Products directly from RISCO or from an authorized distributor of RISCO. RISCO does not warrant the Product to consumers and nothing in this Warranty obligates RISCO to accept Product returns directly from end users who purchased the Products for their own use from RISCO’s customer or from any installer of RISCO, or otherwise provide warranty or other services to any such end user directly. RISCO’s authorized distributor or installer shall handle all interactions with its end users in connection with this Limited Warranty. RISCO’s authorized distributor or installer shall make no warranties, representations, guarantees or statements to its end users or other third parties that suggest that RISCO has any warranty or service obligation to, or any contractual privity with, any recipient of a Product.

Remedies. In the event that a material defect in a Product is discovered and reported to RISCO during the Warranty Period, RISCO shall accept return of the defective Product in accordance with the below RMA procedure and, at its option, either (i) repair or have repaired the defective Product, or (ii) provide a replacement product to the customer.

Return Material Authorization. In the event that you need to return your Product for repair or replacement, RISCO will provide you with a Return Merchandise Authorization Number (RMA#) as well as return instructions. Do not return your Product without prior approval from RISCO. Any Product returned without a valid, unique RMA# will be refused and returned to the sender at the sender’s expense. The returned Product must be accompanied with a detailed description of the defect discovered (“Defect Description”) and must otherwise follow RISCO’s then-current RMA procedure published in RISCO’s website at www.riscogroup.com in connection with any such return. If RISCO determines in its reasonable discretion that any Product returned by customer conforms to the applicable warranty (“Non-Defective Product”), RISCO will notify the customer of such determination and will return the applicable Product to customer at customer’s expense. In addition, RISCO may propose and assess customer a charge for testing and examination of Non-Defective Product.

Entire Liability. The repair or replacement of Products in accordance with this Limited Warranty shall be RISCO’s entire liability and customer’s sole and exclusive remedy in case a material defect in a Product is discovered and reported as required herein. RISCO’s obligation and this Limited Warranty are contingent upon the full payment by customer for such Product and upon a proven weekly testing and examination of the Product functionality.

Limitations. This Limited Warranty is the only warranty made by RISCO with respect to the Products. The warranty is not transferable to any third party. To the maximum extent permitted by applicable law, this Limited Warranty shall not apply and will be void if: (i) the conditions set forth above are not met (including, but not limited to, full payment by customer for the Product and a proven weekly testing and examination of the Product functionality); (ii) if the Products or any part or component thereof: (a) have been subjected to improper operation or installation; (b) have been subject to neglect, abuse, willful damage, abnormal working conditions, failure to follow RISCO’s instructions (whether oral or in writing); (c) have been misused, altered, modified or repaired without RISCO’s written approval or combined with, or installed on products, or equipment of the customer or of any third party; (d) have been damaged by any factor beyond RISCO’s reasonable control such as, but not limited to, power failure, electric power surges, or unsuitable third party components and the interaction of software therewith or (e) any failure or delay in the performance of the Product attributable to any means of communication provided by any third party service provider, including, but not limited to, GSM interruptions, lack of or internet outage and/or telephony failure. BATTERIES ARE EXPLICITLY EXCLUDED FROM THE WARRANTY AND RISCO SHALL NOT BE HELD RESPONSIBLE OR LIABLE IN RELATION THERETO, AND THE ONLY WARRANTY APPLICABLE THERETO, IF ANY, IS THE BATTERY MANUFACTURER’S WARRANTY. RISCO does not install or integrate the Product in the end user’s security system and is therefore not responsible for and cannot guarantee the performance of the end user’s security system which uses the Product or which the Product is a component of.

This Limited Warranty applies only to Products manufactured by or for RISCO. Further, this Limited Warranty does not apply to any software (including operating system) added to or provided with the Products or any third-party software, even if packaged or sold with the RISCO Product. Manufacturers, suppliers, or third parties other than RISCO may provide their own warranties, but RISCO, to the extent permitted by law and except as otherwise specifically set forth herein, provides its Products “AS IS”. Software and applications distributed or made available by RISCO in conjunction with the Product (with or without the RISCO brand), including, but not limited to system software, as well as P2P services or any other service made available by RISCO in relation to the Product, are not covered under this Limited Warranty. Refer to the Terms of Service at: <https://riscocloud.com/ELAS/WebUI/UserLogin/License> for details of your rights and obligations with respect to the use of such applications, software or any service. RISCO does not represent that the Product may not be compromised or circumvented; that the Product will prevent any personal injury or property loss by burglary, robbery, fire or otherwise, or that the Product will in all cases provide adequate warning or protection. A properly installed and maintained alarm may only reduce the risk of a burglary, robbery or fire without warning, but it is not insurance or a guarantee that such will not occur or will not cause or lead to personal injury or property loss. CONSEQUENTLY, RISCO SHALL HAVE NO LIABILITY FOR ANY PERSONAL INJURY, PROPERTY DAMAGE OR OTHER LOSS BASED ON ANY CLAIM AT ALL INCLUDING A CLAIM THAT THE PRODUCT FAILED TO GIVE WARNING.

EXCEPT FOR THE WARRANTIES SET FORTH HEREIN, RISCO AND ITS LICENSORS HEREBY DISCLAIM ALL EXPRESS, IMPLIED OR STATUTORY, REPRESENTATIONS, WARRANTIES, GUARANTEES, AND CONDITIONS WITH REGARD TO THE PRODUCTS, INCLUDING BUT NOT LIMITED TO ANY REPRESENTATIONS, WARRANTIES, GUARANTEES, AND CONDITIONS OF MERCHANTABILITY, FITNESS FOR A PARTICULAR PURPOSE, TITLE AND WARRANTIES AGAINST HIDDEN OR LATENT DEFECTS, TO THE EXTENT PERMITTED BY LAW. WITHOUT LIMITING THE GENERALITY OF THE FOREGOING, RISCO AND ITS LICENSORS DO NOT REPRESENT OR WARRANT THAT: (i) THE OPERATION OR USE OF THE PRODUCT WILL BE TIMELY, SECURE, UNINTERRUPTED OR ERROR-FREE; (ii) THAT ANY FILES, CONTENT OR INFORMATION OF ANY KIND THAT MAY BE ACCESSED THROUGH THE PRODUCT SHALL REMAIN SECURED OR NON DAMAGED. CUSTOMER ACKNOWLEDGES THAT NEITHER RISCO NOR ITS LICENSORS CONTROL THE TRANSFER OF DATA OVER COMMUNICATIONS FACILITIES, INCLUDING THE INTERNET, GSM OR OTHER MEANS OF COMMUNICATIONS AND THAT RISCO'S PRODUCTS, MAY BE SUBJECT TO LIMITATIONS, DELAYS, AND OTHER PROBLEMS INHERENT IN THE USE OF SUCH MEANS OF COMMUNICATIONS. RISCO IS NOT RESPONSIBLE FOR ANY DELAYS, DELIVERY FAILURES, OR OTHER DAMAGE RESULTING FROM SUCH PROBLEMS. RISCO WARRANTS THAT ITS PRODUCTS DO NOT, TO THE BEST OF ITS KNOWLEDGE, INFRINGE UPON ANY PATENT, COPYRIGHT, TRADEMARK, TRADE SECRET OR OTHER INTELLECTUAL PROPERTY RIGHT IN ANY EVENT RISCO SHALL NOT BE LIABLE FOR ANY AMOUNTS REPRESENTING LOST REVENUES OR PROFITS, PUNITIVE DAMAGES, OR FOR ANY OTHER INDIRECT, SPECIAL, INCIDENTAL, OR CONSEQUENTIAL DAMAGES, EVEN IF THEY WERE FORESEEABLE OR RISCO HAS BEEN INFORMED OF THEIR POTENTIAL.

Contacting RISCO Group

RISCO Group is committed to customer service and product support. You can contact us through our website (www.riscogroup.com) or at the following telephone and fax numbers:

United Kingdom

Tel: +44-161-655-5500
technical@riscogroup.co.uk

Italy

Tel: +39-02-66590054
support@riscogroup.it

Spain

Tel: +34-91-490-2133
support-es@riscogroup.com

France

Tel: +33-164-73-28-50
support-fr@riscogroup.com

Belgium

Tel: +32-2522-7622
support-be@riscogroup.com

USA

Tel: +305-592-3820
support@riscogroupusa.com

China

Tel: +86-21-52-39-0066
support-cn@riscogroup.com

Israel

Tel: +972-3-963-7777
support@riscogroup.com

All rights reserved.

No part of this document may be reproduced in any form without prior written permission from the publisher.



© RISCO Group 01/19

5IN2628 B