



CONNECT TO
MYKEYS **PRO**



NETWORK
WITH US



**ITALY AND OTHER COUNTRIES
SILCA S.p.A.**

Via Podgora, 20 (Z.I.)
31029 VITTORIO VENETO (TV)
Phone +39 0438 9136
Fax +39 0438 913800
E-mail: silca@silca.it
Italy: www.silca.it
International Markets: www.silca.biz

**SPAIN
SILCA KEY SYSTEMS S.A.**

Avinguda Conflent, 52 Nave 7
08915 BADALONA
Phone: +34 93 4981400
E-mail: silca@silca.es
www.silca.es

**GERMANY
SILCA GmbH**

Siemensstrasse, 33
42551 VELBERT
Phone: +49 2051 2710
Fax +49 2051 271172
E-mail: info@silca.de
www.silca.de

**BENELUX
H. CILLEKENS & B.V.**

Metaalweg, 4
6045 JB ROERMOND
Phone: +31 475 325147
Fax +31 475 323640
E-mail: info@hcillekens.nl
www.hcillekens.nl

**FRANCE
SILCA S.A.S**

12, Rue de Rouen
Z.I. Limay-Porcheville
78440 PORCHEVILLE
Phone: +33 1 30983500
Fax +33 1 30983501
E-mail: info@silca.fr
www.silca.fr

**UNITED KINGDOM
SILCA LTD. & ADVANCED
DIAGNOSTICS Ltd.**

Eastboro Fields
Hemdale Business Park
CV11 6GL Nuneaton
United Kingdom
www.silca.co.uk



dormakaba Group

QUATTROCODE *D700*

CUTS AND ENGRAVES DIMPLE AND LASER KEYS IN ONE SINGLE PROCESS

Designed for specialist locksmiths, the Silca Quattrocode D700 cuts and engraves dimple and laser keys in one single process to improve the speed and quality of service to your customer. Thanks to the robot arm, which turns and positions the key automatically, keys are cut and engraved without needing to be manually re-positioned.

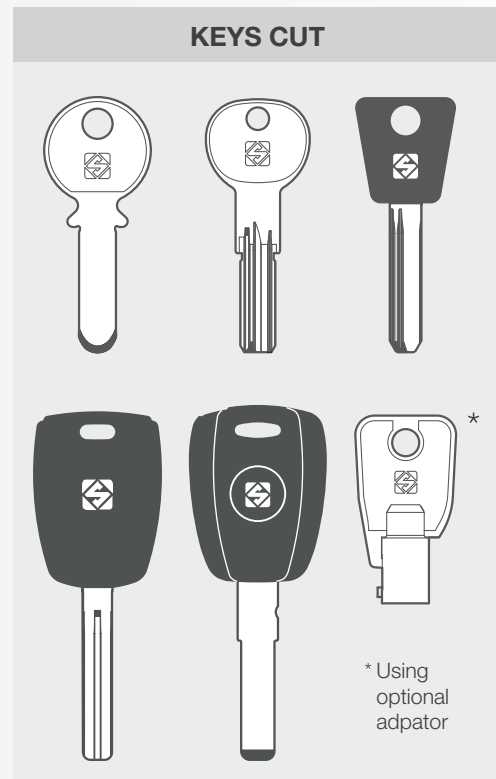

CE Quattrocode D700 has been designed and manufactured in conformity with CE mark European standards.

ROBOT ARM FOR AUTOMATIC KEY ROTATION

- The robot turns the key automatically to cut all 4 sides of the blade.
- Once the key to be cut is positioned in the jaws, the machine automatically completes the cutting and engraving cycle.
- No further manual intervention is required, freeing up the key cutter's time for other tasks.

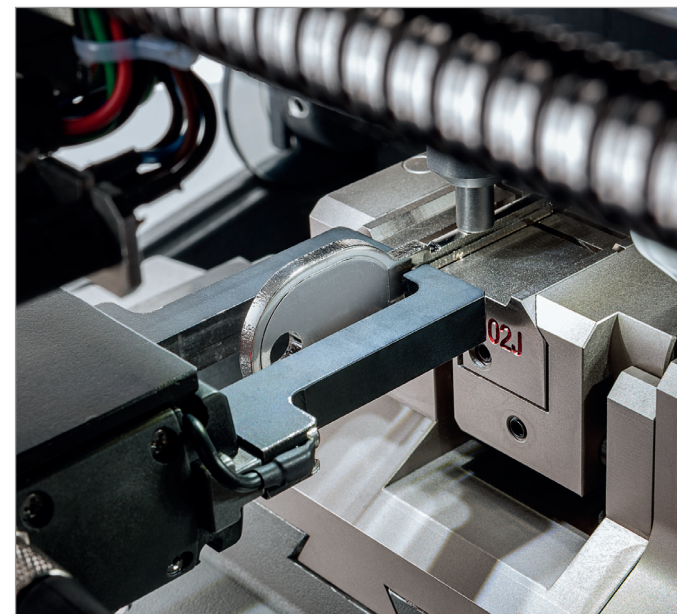

20% FASTER KEY CUTTING**

- Variable speed motors allow higher spindle speeds, up to 25000 rpm or 6000 rpm faster than previous models if using original Silca cutters.
- A fully automated key cutting process saves set-up time and eliminates mistakes.
- The key cutter can tailor the speed to suit the specific key to be cut, choose a faster speed to reduce the job queue or reduce the speed to prolong cutter life.

** Compared to Triax Pro

FULLY AUTOMATED KEY CUTTING PROCESS

- An in-built video camera checks the key head size is within the limits to be handled by the robot arm.
- To ensure a precision cut, compressed air is blown onto the jaws to clean away swarf before the key is repositioned.
- A press is lowered onto the key to ensure correct positioning in the jaws.

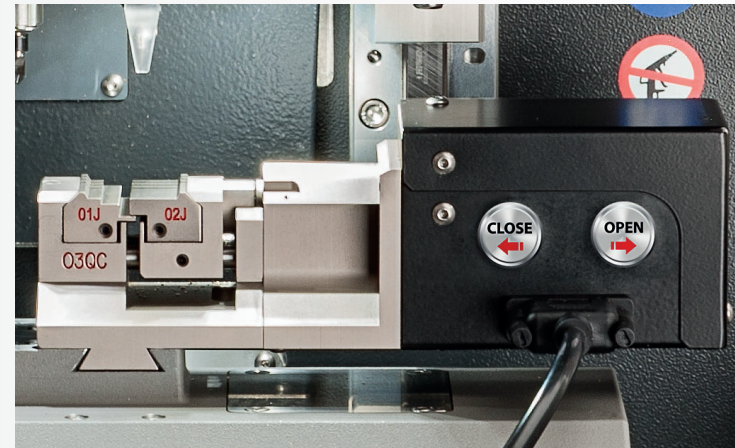

ELECTRONIC CLAMP OPENING AND CLOSING

- The clamp is opened and closed electronically by pressing the push buttons positioned at the side of the clamp.
- Once the cutting cycle begins, the clamp is opened and closed automatically to allow the robot arm to turn and position the key.
- An electronic closure guarantees that exactly the right pressure is used to clamp the key correctly in the jaws.

INTEGRATED ENGRAVING

- Keys are both cut and engraved in one single, automatic process.
- The D700 contains a dedicated, hard metal engraving cutter on board ready for use without the need for manual intervention.
- Process time is dramatically reduced, no need to install a separate cutter or to reposition the key for engraving.



AUTOMATIC TRACER POSITIONING

- For decoding the original key, the tracer is lowered and raised automatically.
- No need to manually position the tracer.
- If necessary, the original key is then turned and repositioned automatically by the robot arm to complete the decoding process.

AUTOMATIC CUTTER RECOGNITION USING RFID

- All Quattrocode D700 cutters contain an RFID tag that can be detected by the machine.
- The RFID connection ensures that the correct cutter for the key to be duplicated is always used.
- To avoid error and wasted effort, the machine will not progress the cutting cycle if an incorrect cutter is fitted.

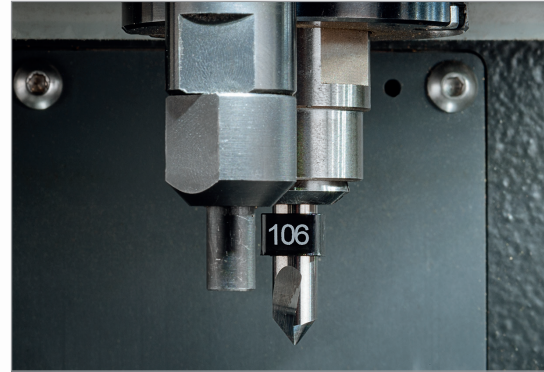

REDUCE DOWNTIME

- RFID recognition means information on specific cutter usage is available in the machine memory to help guide replacement needs and avoid work interruptions.
- To maintain optimum cutting performance and to ensure continuous operation, the machine can be set to send a notification by email when a cutter reaches a preimposed level of use.

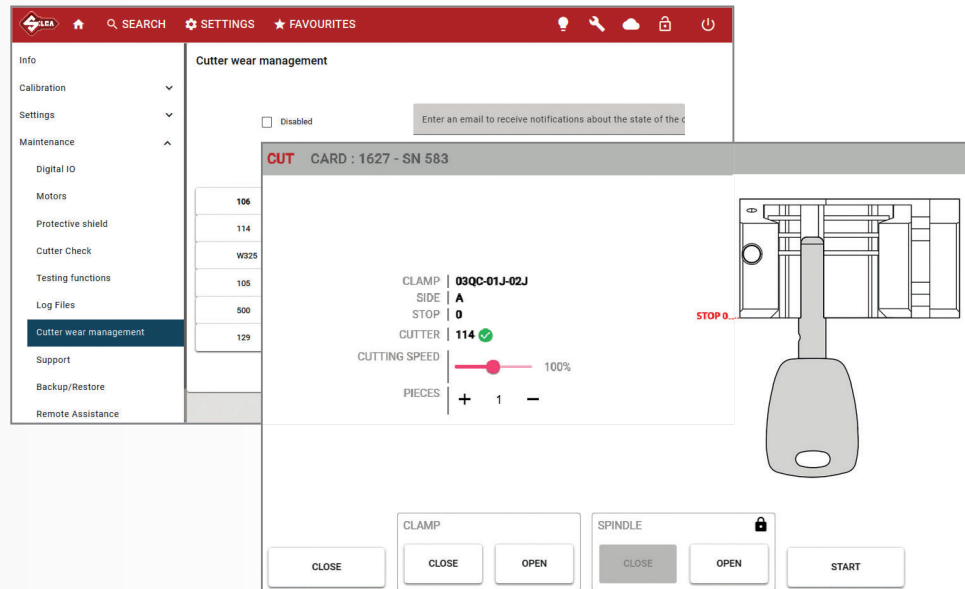

EASY CUTTER MANAGEMENT

- For quick, visual identification, all the Quattrocode cutters have a collar labelled with the cutter number.
- A telescopic pull-out drawer has been designed to hold 18 cutters, keeping them close at hand.
- Cutters can be changed easily, the spindle is opened and closed electronically from the machine display.
- Silca offers a range of over 100 dedicated cutters enabling the D700 to duplicate the vast majority of original dimple and laser keys available on the market.

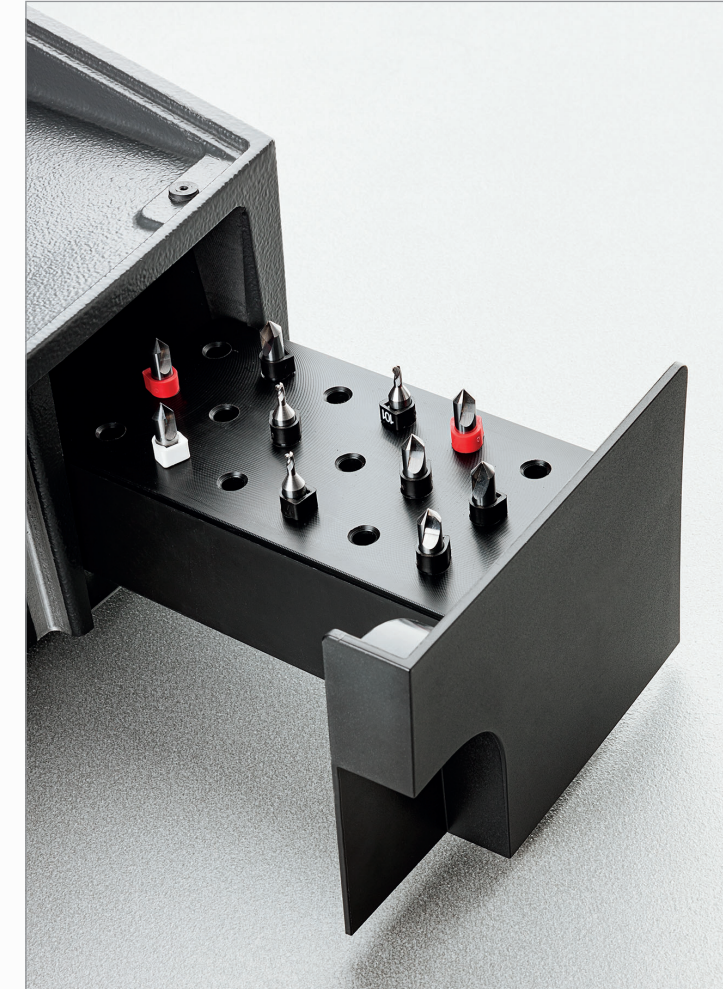

COLLAR LABELED CUTTERS

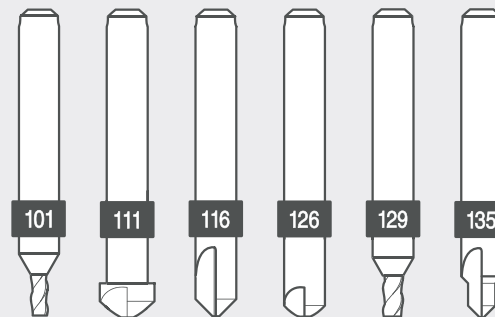



USER-FRIENDLY SOFTWARE INTERFACE

- Intuitive software interface developed for the needs of professional locksmiths, with shortcuts to the most used cutting cards and job queues.
- Works in stand-alone.
- Compatible with SKP Pro to work with existing data archives and Codemaker cards.

PROFESSIONAL DISPLAY

- Integrated, industrial 10-inch, touch-screen display.
- Tilts to give the perfect viewing angle.
- Immediate response to the touch (0,01 seconds).
- Colour display with a resolution of 1280x800 pixels.

FULL CONNECTIVITY

- Connection both via Wi-Fi and via Ethernet to the local LAN network.
- 4 USB ports (2 ports 3.0 + 2 ports 2.0)
- HDMI port to connect an external screen.
- Possibility to connect a wireless keyboard and mouse.

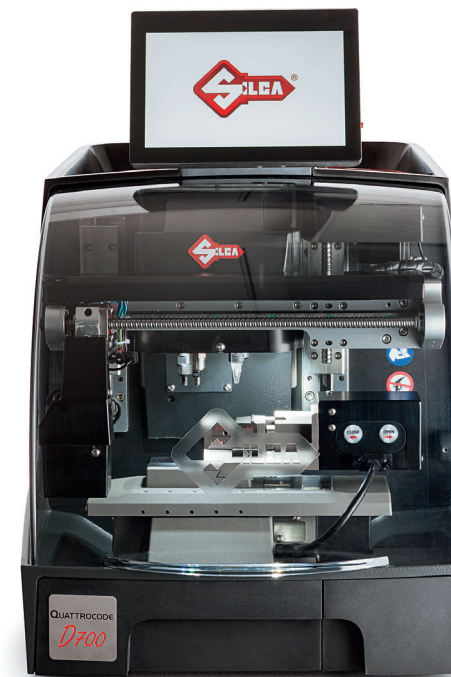

CLEANER, SAFER AND MORE PRACTICAL WORKING AREA

- The machine is completely enclosed: swarf is collected in the tray below the cutting area to leave the working area clean.
- The safety shield closes and opens automatically when starting or ending a cycle.
- The shield features two microswitches and stops automatically if obstructed to give additional protection.
- 55% bigger working area compared to previous models for easier operation.



QUIET

- New, heavier structure optimized to reduce vibrations and noise.
- A completely enclosed working area reduces noise during engraving and cutting.

QUATTROCODE D700 SOFTWARE

Entirely new software has been designed for the Quattrocode D700, engineered specifically to make key duplication easier and quicker. The important feature innovations on the D700 are fully supported in the software to give instant feedback in the display, ensuring a smooth cutting operation.

- Cutting cards comparison available on board.
- See a preview of the cuts.
- Select favourites, rename the cutting cards used most frequently and reorder them according to need.
- Confirmation of the correct cutter being fitted or, if not, the right code number to use.
- Code tables available on board.
- Onboard video tutorials and product manual.
- Remote service to support you when needed.
- Photo feedback on the compatibility of the key head with the robot arm.

CUTTING CARD

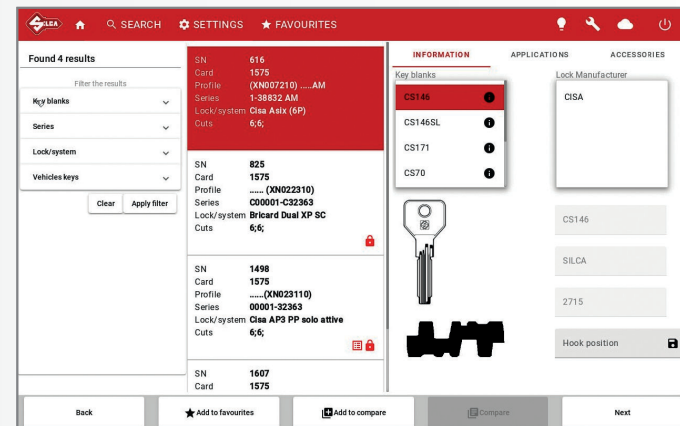

CUT PREVIEW

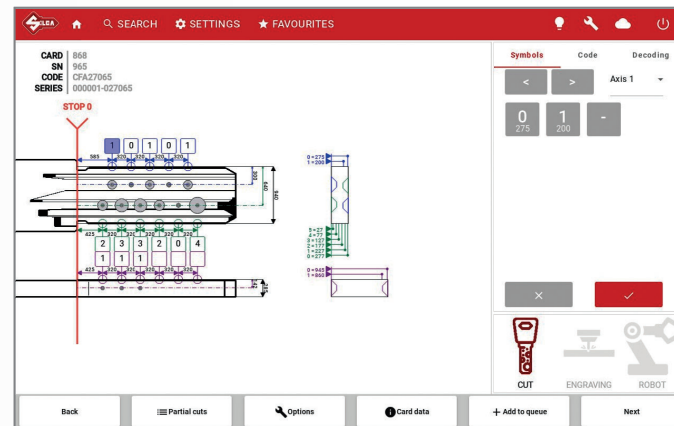

VIDEO CAMERA DETECTS KEY HEAD DIMENSIONS

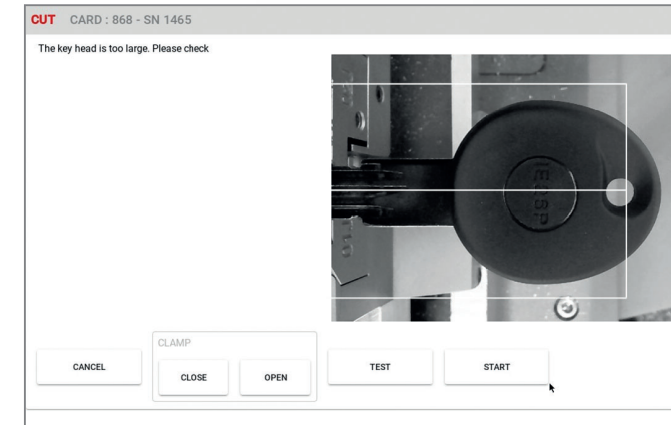

FAVOURITES

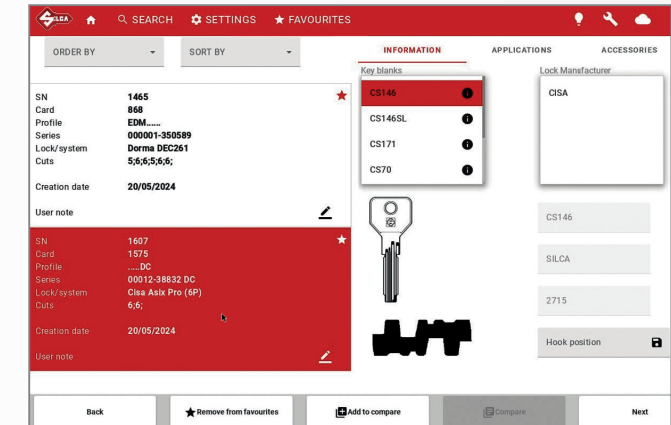

CUTTER RECOGNITION

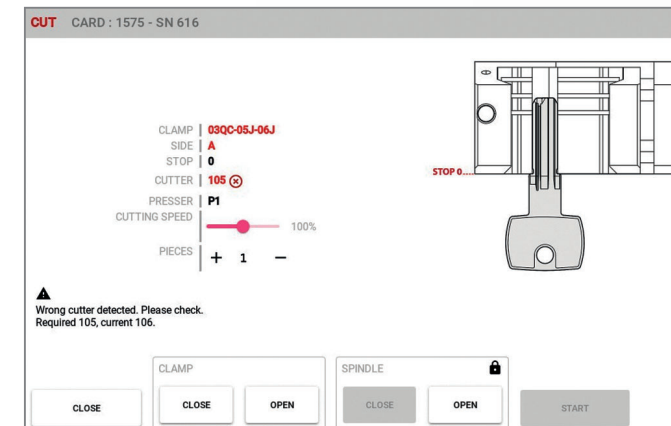

Precision Performance



Fully automated process



Compatible with SKP Pro



Remote Assistance



Speed



Safety

QUATTROCODE **D700** IN NUMBERS

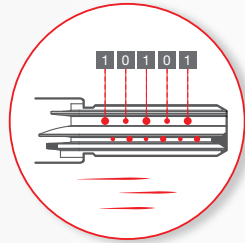

20% faster
cutting cycle compared
to previous models

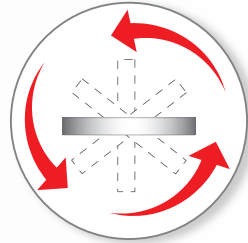

4-sided key rotation
for a completely
automatic cutting cycle



0 key set-up time
for a completely automatic
engraving process

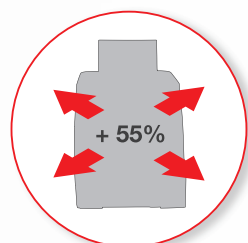

55% bigger
working
area

PATENT PENDING SOLUTIONS

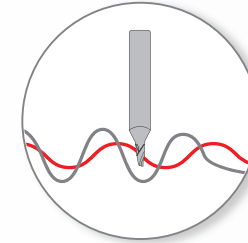

RFID
cutter detection

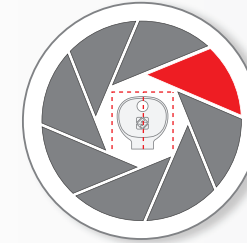

Video camera
to check key
head size

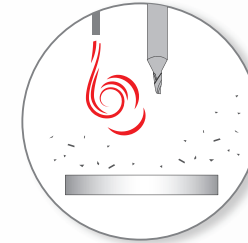

Compressed air
blower to remove
swarf

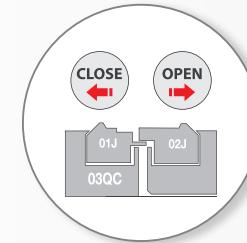

Electronic clamp
with push-button
control

TECHNICAL DATA

Electricity supply	100-240V - 50/60Hz
Cutter motor	48VDC
Engraving motor	24VDC
Key cutter	Cutter in hard metal
Engraving cutters	Cutter in hard metal
Tool speed	Key cutter: 25000 rpm Engraving cutter: 22000 rpm
Clamping trolley movements	on 3 axes with ball screws activated by step motors on ground roller runners
Electronic clamp 03QC	Removeable and equipped with interchangeable jaws
Robot movement	On axis with ball screws activated by step motors on ground roller runners.
Runs	With clamp: axis X 80mm, axis Y 77mm, axis Z 40mm
Noise level - equivalent noise level (leq) dBA	Steel laser key cutting: 65,1 / Brass laser key cutting: 65,4 / Silver-nickel dimple key cutting cycle: 65,5 / Brass dimple key cutting cycle: 64,0
Max dimensions	Height 680 mm, Width 502 mm, Depth 740 mm
Weight	76,5 kg

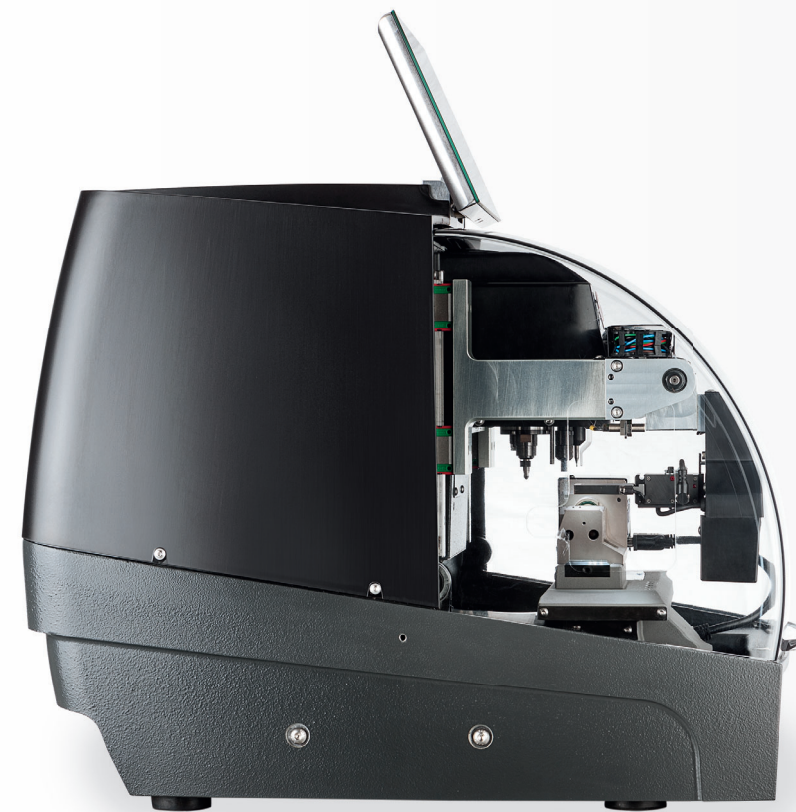

LEGAL NOTES - In compliance with current regulations relating to industrial property, please note that - but for "Silca", "dormakaba", "Kaba", "Ilco" and "Advanced Diagnostics" - the trademarks or trade names mentioned in our document are the exclusive property of third parties not affiliated nor linked with Silca S.p.A. or the dormakaba Group. Silca S.p.A. and dormakaba Group do not own any intellectual property right nor have been granted any license with regard to such trademarks and trade names, which are hereby used only to indicate the intended purpose of Silca's products. / This catalogue is reserved exclusively for professional key cutters who use Silca products. The illustrations and technical data regarding the products in the document are to be considered indicative. Silca reserves the right to alter products designs, dimensions or info to improve the products quality. The contents of this document are fully protected by Copyright and may not be copied or reproduced in any form, without written permission from Silca S.p.A. For any dispute the competent Court is that of Treviso, the applicable law is that of Italy.